



Morsettiere

Morsettiere 56x36 a 3/4/5/6 perni M5

Perno standard in ottone. A richiesta in ferro zincato.

Utili in applicazioni specifiche, ad esempio motori asincroni monofase.
N.B. Posizione perni e siglatura a discrezione del cliente.



DATI TECNICI

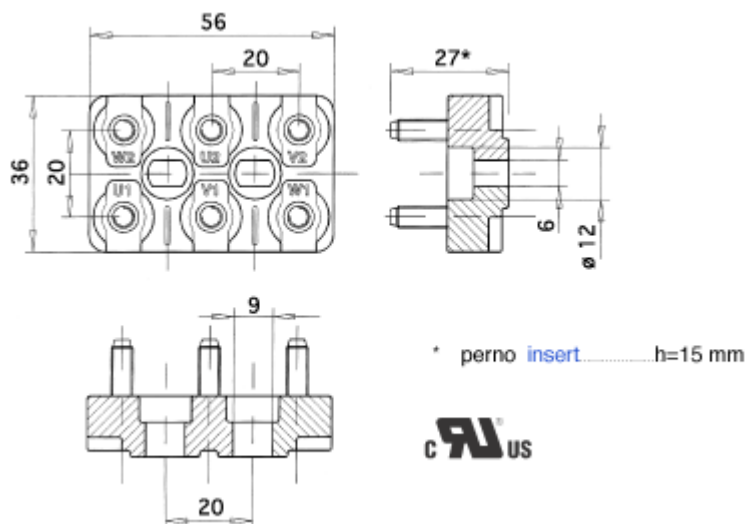

DISEGNI TECNICI PERNI E MINUTERIA E DOVE RICHIESTE, NORME DI RIFERIMENTO

Perno M5	Uni 5541-65 / 5542-65 / 4535-64
Dado M5	Din 934 = Uni 5588
Rondelle M5	
Piastrine M5 interasse 20 mm	
Perno carico di torsione	3 N.m
Certificazioni UL	File n° E213748

MINUTERIA METALLICA A CORREDO

Il corredo potrà essere composto a seconda delle richieste e delle necessità. In tutti i casi il corredo può essere fornito in confezione unica oppure separatamente in sacchetti singoli.

