



Morsettiere

Morsettiere 44x27 3/4/5/6 perni M4

Perno standard in ottone. A richiesta in ferro zincato.

Utili in applicazioni specifiche, ad esempio motori asincroni monofase.
N.B. Posizione perni e siglatura a discrezione del cliente.



DATI TECNICI

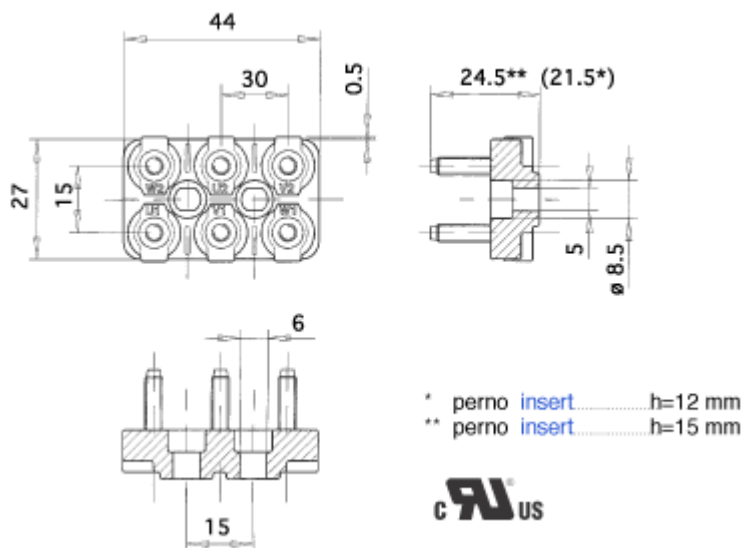

DISEGNI TECNICI PERNI E MINUTERIA E DOVE RICHIESTE, NORME DI RIFERIMENTO

Perno M4	Uni 5541-65 / 5542-65 / 4535-64
Dado M4	Din 934 = Uni 5588
Rondelle M4	
Piastrine M4 interasse 15 mm	
Perno carico di torsione	2 N.m
Certificazioni UL	File n° E213748

MINUTERIA METALLICA A CORREDO

Il corredo potrà essere composto a seconda delle richieste e delle necessità. In tutti i casi il corredo può essere fornito in confezione unica oppure separatamente in sacchetti singoli.

