

Morsettiere

Morsettiera 70x45 a 3/4/5/6 perni M6

Perno standard in ottone. A richiesta in ferro zincato.



Utili in applicazioni specifiche, ad esempio motori asincroni monofase per settore pompe.

N.B. Posizione perni e siglatura a discrezione del cliente.

DATI TECNICI

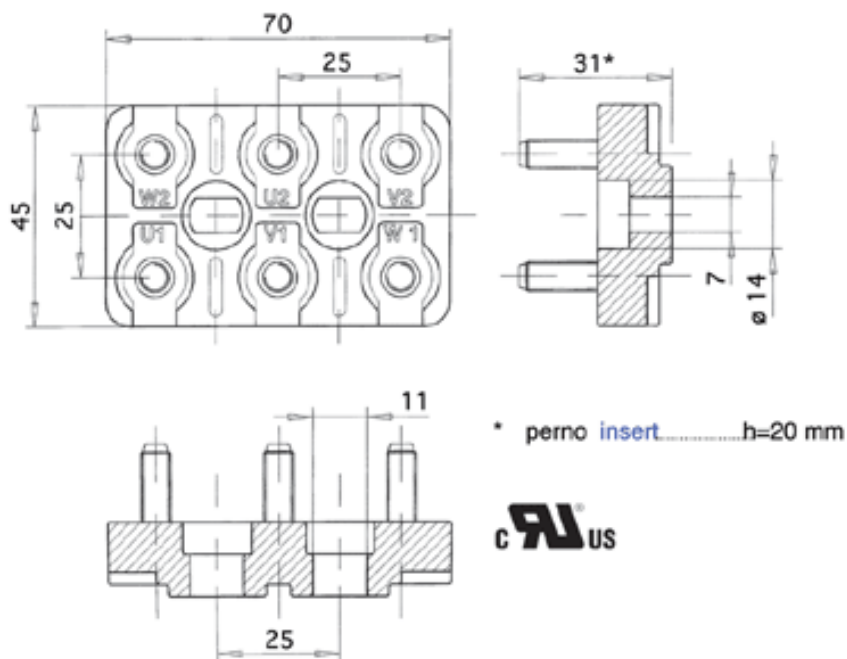

DISEGNI TECNICI PERNI E MINUTERIA E DOVE RICHIESTE, NORME DI RIFERIMENTO

Perno M6

Uni 5541-65 / 5542-65 / 4535-64

Dado M6

Din 934 = Uni 5588

Rondelle M6	
Piastrine M6 interasse 25 mm	
Perno carico di torsione	
Certificazioni UL	

Nessuna norma precisa;

4 N.m

File n° E213748

MINUTERIA METALLICA A CORREDO

Il corredo potrà essere composto a seconda delle richieste e delle necessità. In tutti i casi il corredo può essere fornito in confezione unica oppure separatamente in sacchetti singoli.

